



Owner's Manual

Front Mount Electric Winch Model Quick Mount 9000/9500



Congratulations!

You have purchased the finest winch available in its service class. The Quick Mount™ is a detachable winch. It can be easily mounted to the front or rear of a vehicle for self recovery and other applications. It allows one winch to be used on multiple vehicles, and can be quickly installed and removed to avoid extra vehicle weight.

The Quick Mount™ comes with a remote control switch, anti-theft locking pin and a hawse fairlead. Front mount requires a front receiver mounting kit. Optional 5 ft., 20 ft. or 24 ft. battery cables for front or rear mounting are available.

The Quick Mount™ features a highly efficient 3 stage planetary gear set which transmits torque from a series wound D.C. motor. A positive clutch allows free spooling for quick cable deployment. An automatic load holding brake is designed to hold the full rated capacity of the winch. It was designed and manufactured to provide you with the utmost in utility. As with any device that combines power and movement in its use, there are dangers if improperly used. At the same time, there are easier and faster ways for getting the job done if certain precautions are taken first.

Please read this manual carefully. It contains useful ideas in obtaining the most efficient operation from your Ramsey Winch and safety procedures you need to know before beginning use.

When you follow our guidelines for operation, your Ramsey Winch will give you many years of satisfying service. Thank you for choosing Ramsey. You will be glad you have one working for you.



CAUTION: Read and understand this manual before installation and operation of winch. See Safety Precautions.

QUICK MOUNT 9000						
Layer of Cable		1	2	3	4	5
Rated Line Pull Per Layer	(lbs)	9,000	7,300	6,200	5,400	4,700
	(kg)	4,070	3,300	2,800	2,440	2,130
Cumulative Cable Capacity Per Layer (5/16" - 8mm - dia. Cable)	(ft)*	15	35	60	90	105
	(m)*	4	10	18	27	32
Line Pull First Layer	(lbs)	NO	2,000	4,000	6,000	9,000
	(kg)	LOAD	900	1,810	2,720	4,070
Line Speed First Layer	(FPM)	29	15	11	9	7
	(MPM)	8.8	4.6	3.3	2.7	2.1
Amp Draw (12V)		90	190	245	315	400

QUICK MOUNT 9500							
Layer of Cable		1	2	3	4	5	
Rated Line Pull Per Layer	(lbs)	9,500	7,700	6,500	5,700	4,900	
	(kg)	4,309	3,480	2,940	2,580	2,210	
Cumulative Cable Capacity Per Layer (5/16" - 8mm - dia. Cable)	(ft)*	15	34	58	86	100	
	(m)*	4	10	17.5	26	30.5	
Line Pull First Layer	(lbs)	NO	2,000	4,000	6,000	8,000	9,500
	(kg)	LOAD	900	1,810	2,720	3,620	4,309
Line Speed First Layer	(FPM)						
	12V	34.5	16.7	12.7	10.6	9	7.8
	24V	29	16	13	10	9	8
	(MPM)						
AMP DRAW	12V	97	180	260	335	395	430
	24	45	95	128	165	192	212

*DEPENDS ON CABLE BEING UNIFORMLY WOUND ONTO DRUM.

Ramsey performance data is compiled from actual winch testing.

Please Note: Ramsey Quick Mount™ series winches are designed for front and rear mount vehicle use. The winches are not designed for and should not be used in industrial applications (car haulers /carriers, wreckers, hoisting, etc.), and Ramsey does not warrant them to be suitable for such use. Ramsey makes a separate, complete line of winches for industrial/commercial use. Please contact the factory for additional information.

Contents

Performance Specifications	Front Cover
Safety Precautions.....	2
Tips for Safe Operation	2
Techniques of Operation	3
Assembling Your Winch.....	4
Electrical Connections	5
Installation.....	5
Clutch Operation.....	6
Remote Control Operation.....	6
Maintenance.....	6
Cable Installation	7
Troubleshooting Guide	7
Winch Parts List.....	8-10
Warranty	Back Cover



Safety Precautions To Guard Against Possible Injury.....

A minimum of five wraps of cable around the drum barrel is necessary to hold the rated load. Cable clamp is not designed to hold the load.

- A. Secure Quick Mount™ locking pin into place before starting winching operation.
- B. Use only locking pin #448097.
- C. Front mount receiver is for use with the Quick Mount™ winch only. Do not use for towing.
- D. Keep yourself and others a safe distance to the side of the cable when pulling under load.
- E. Do not step over a cable, or near a cable under load.
- F. Use supplied hook strap when handling hook for spooling wire rope.
- G. Do not move the vehicle to pull a load on the winch cable. This could result in cable breakage and/or winch damage.
- H. Use a heavy rag or gloves to protect hands from burrs when handling winch cable.
- I. Apply blocks to wheels when vehicle is on an incline.
- J. Winch clutch should be disengaged when winch is not in use and fully engaged when in use.
- K. Modification, alteration, or deviation to the winch should only be made by Ramsey Winch Company.
- L. Keep the duration of your pulls as short as possible. If the motor becomes uncomfortably hot to the touch, stop and let it cool for a few minutes. Do not pull more than one minute at or near the rated load. Do not maintain power to the winch if the motor stalls. Electric winches are for intermittent usage and should not be used in constant duty applications.
- M. Disconnect the remote control switch from the winch when not in use. A Ramsey Part No. 282053 battery disconnect switch in your vehicle is recommended.
- N. Do Not use winch in hoisting applications due to required hoist safety factors and features.
- O. Do not exceed maximum line pull ratings shown in tables. Shock loads must not exceed these ratings.

- P. To respool correctly, it is necessary to keep a slight load on the cable. This is accomplished by (wearing gloves) holding the cable with one hand and the remote control with the other, starting as far back and in the center as you can, walking up keeping load on the cable as the winch is powered in. Do not allow the cable to slip through your hand and do not approach the winch too closely. Turn off the winch and repeat the procedure until all the cable except a few feet is in. Disconnect the remote control switch and finish spooling in cable by rotating the drum by hand with clutch disengaged.



Tips for Safe Operation

Do not underestimate the potential danger in winching operations. Neither should you fear them. Do learn the basic dangers and avoid them.

Observe spooling of cable onto drum. Side pulls can cause cable to pile up at one end of the drum. To correct uneven stacking, spool out that section of the cable and move it to the other end of the drum and continue winching. Uneven spooling which causes cable pileup can interfere with the solenoid housing causing damage to the winch.

Store the remote control switch inside your vehicle where it will not become damaged. Inspect it before you plug it in.

When ready to begin spooling in, plug in remote control switch with clutch disengaged. Do not engage clutch with motor running.

Never connect the hook back to the cable. This causes cable damage. Always use a sling or chain of suitable strength as shown in the illustration, page 3.

Observe your winch while winching, if possible, while standing at a safe distance. If you use vehicle drive to assist, stop and get out every few feet to assure the cable is not piling up in one corner. Jamming cable can break your winch.

Do not attach tow hooks to winch mounting apparatus. They must attach to vehicle frame.

When double lining during stationary winching, the winch hook should be attached to the chassis of the vehicle.

Since the greatest pulling power is achieved on the innermost layer of your winch, it is desirable to pull off as much line as you can for heavy pulls. If this is not practical, use a snatch block and double line arrangement as shown in the illustration, page 3. Remember, a minimum of 5 wraps of cable around the drum barrel is necessary to hold the rated load.

Neat, tight spooling avoids cable binding. Cable binding occurs when a cable under load pulls down into the layer below, becoming pinched between two other wraps of cable. If this happens, alternately power the winch in and out a few inches. Do not attempt to work a bound cable under load; free by hand.

Techniques of Operation

The best way to get acquainted with how your winch operates is to make a few test runs before you actually need to use it. Plan your test in advance. Remember you hear your winch as well as see it operate. Get to recognize the sound of a light steady pull, a heavy pull, and sounds caused by load jerking or shifting. Soon you will gain confidence in operating your winch and its use will become second nature with you.

When pulling a heavy load, place a blanket, jacket or tarpaulin over the cable five or six feet from the hook. It will slow the snap back in the event of a broken cable. Also, open the vehicle hood for additional protection.

Use the vehicle wheel power to help the winch, but do not overtake the winch line. Plan your pull. You can not always hook up and pull out in one step. Examine the area for anchoring possibilities as well as leverage situations, direction, and goal.

Your winch will not only pull you up or ease you down a steep grade, it will also pull another vehicle or a load while your vehicle is anchored in a stationary position.

The following illustrations show a few basic winching techniques.



For basic self recovery, anchor to a tree or heavy rock. When anchoring to a tree, always use a tree trunk protector.

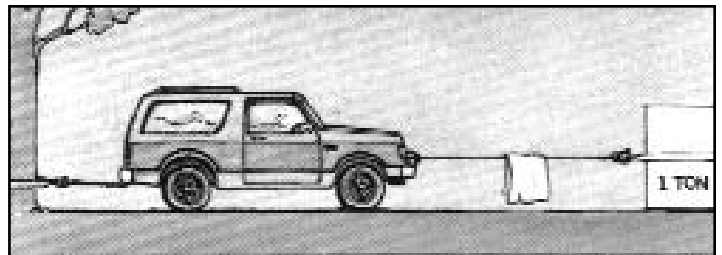

For a direct pull of 2,000 lbs., hitch truck to a tree or solid anchor, and take out of gear.



Stakes driven in solid earth and chained together make a good anchor point for self-recovery when no solid anchor point is available.

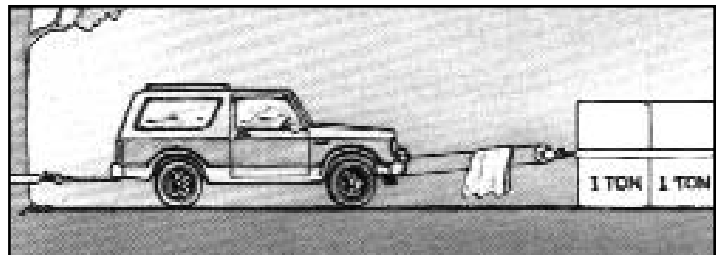

To double the pull, use 2-part line with snatch block and tie off to chassis. Take out of gear.

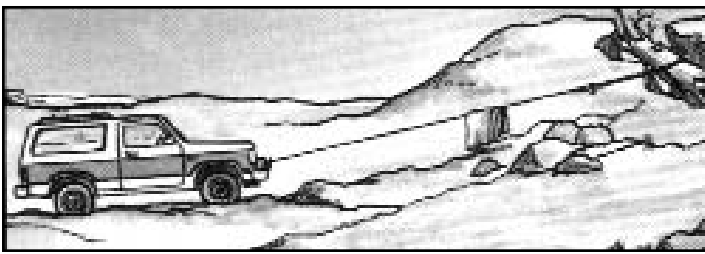

For a solid anchor, bury a log with earth or sand or place it in a deep ravine

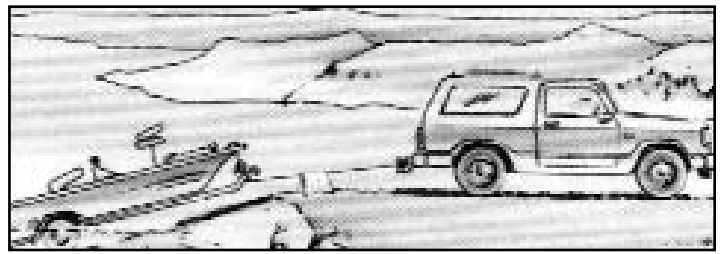

Use for loading and unloading boats, trailers, race cars, etc.

Assembling Your Winch

To assemble the QUICK MOUNT™ attach the handles to both ends of the quick mount channel using (2) black 3/8" button head screws for each handle. Tighten to 20 ft-lbs. torque.

Once the handles are attached, lift the winch into the quick mount channel. Feed the looped end of the pre-wrapped cable through the fairlead.

Place a 3/8" nut and flatwasher in each of the feet. Align the four mounting holes in the quick mount channel with the feet of the winch. Place a lockwasher on each 3/8" hex head screw and then press a screw through each mounting hole and start it through a nut. Do not tighten until all of the screws have been started. Tighten to 34 ft-lbs. torque.

Align the base of the clevis hook with the loop on the end of the cable. Run the pin through the clevis hook and the loop. Push the cotter pin through the hole in the pin and bend the cotter pin to lock.

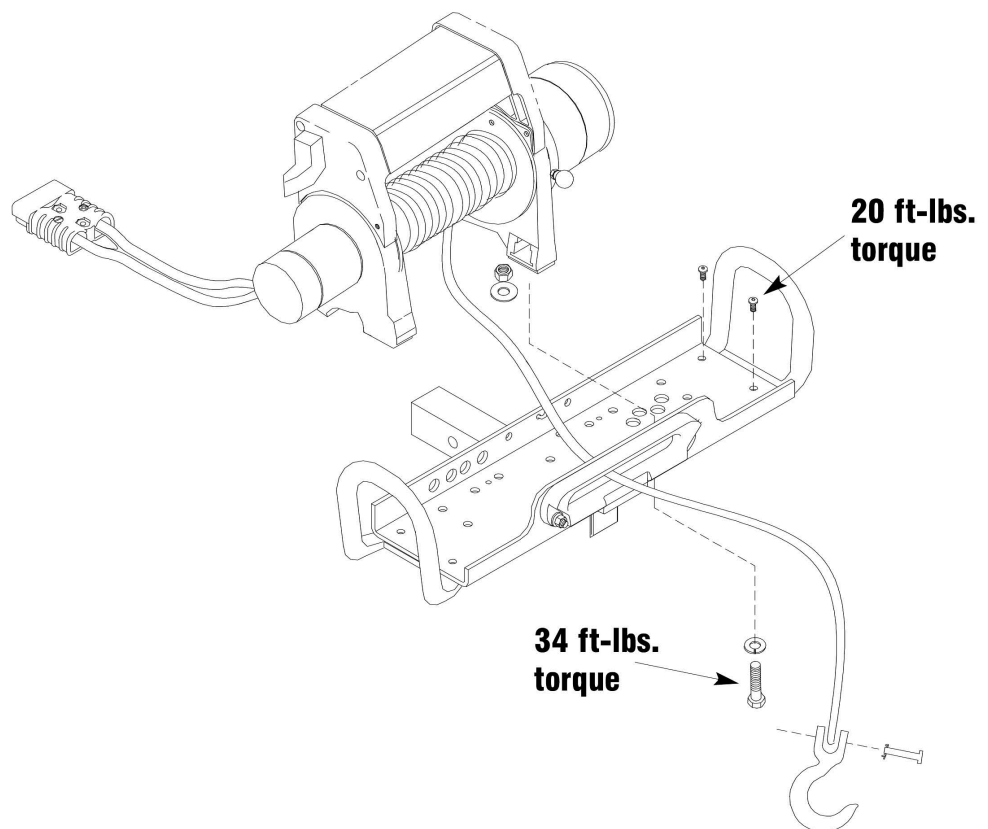

Electrical Connections

For normal self recovery work, your vehicle's existing electrical system is adequate. Your battery must be kept in good condition. A fully charged battery and proper connections are essential.

A Quick Connect battery lead, sold separately, is required. Ramsey makes three lengths of Quick Connect leads:

Part No.	Description
251053	5 ft. (1.5 m) Battery Lead
251021	20 ft. (6.1 m) Battery Lead
251054	24 ft. (7.3 m) Battery Lead

The 5 foot battery lead is used with a front receiver mount, and the 20 or 25 foot battery leads are used with a rear receiver mount, depending on the size of the vehicle.

For front mounting, route quick connect battery lead through grille leaving connector outside and connect red cable to positive (+) battery terminal and black cable to negative (-) battery terminal. Secure cable under hood using cable ties.

For rear mounting, connect battery power leads as described above. Secure cables under vehicle away from moving parts and exhaust system. Terminate routing near the center of the vehicle at the rear. **Be sure battery cables are not drawn taut across any surfaces which could damage them.**

Installation

The Quick Mount™ is solely and exclusively designed for vehicle-mounted, non-industrial applications. All other applications will void warranty.

The Quick Mount™ must be front mounted with a front receiver hitch available from Ramsey for selected vehicles. For rear mounting of the QM, a SurePull Class III rear receiver or equivalent with a 5,000 lb. minimum weight carrying (WC) rating must be used.

Secure Quick Mount™ in the receiver with the Ramsey locking pin. Connect quick disconnect from Quick Mount™ winch to battery power lead. Plug remote switch into receptacle on solenoid assembly.

Clutch Operation

The winch clutch allows rapid unspooling of the wire rope for hooking onto the load or anchor point. The clutch is operated by the shifter knob located as shown below. The operation is as follows:

1. To disengage the clutch, move the clutch shifter knob to the "OUT" position. Wire rope may now be freespooled off the drum.
2. To engage the clutch, move the clutch shifter knob into the "IN" position. The winch is now ready for pulling.

Remote Control Switch Operation

The remote control switch is waterproof and has push button stations on either side. It is designed this way to prevent quick winch reversals which lead to premature solenoid failure. The switch is also color coded to aid you in not having to guess at the direction your winch will run. Make sure the motor has stopped fully before reversing. Run the winch forward and reverse to check connections. Snap appropriate plastic disc into proper thumb button cavity on remote switch after determining direction of rotation for winch drum.

DO NOT LEAVE SWITCH PLUGGED IN WHEN WINCH IS NOT IN USE.

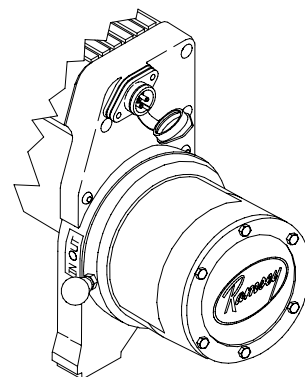
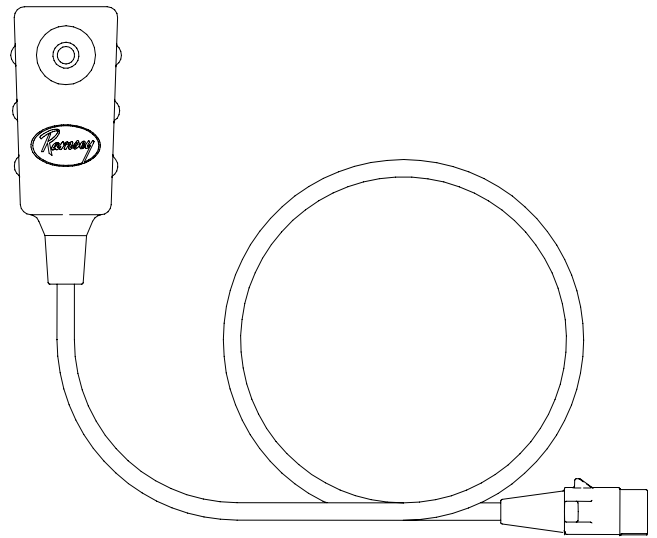

Maintenance

All moving parts are permanently lubricated with high temperature lithium grease at the time of assembly. Under normal conditions factory lubrication will suffice.

Lubricate cable periodically using light penetrating oil. Inspect cable for broken strands and replace if necessary. If the cable becomes worn or damaged, it must be replaced.

Corrosion on electrical connections will reduce performance or may cause a short. Clean all connections especially in the remote control switch and receptacle. In salty environments use a silicone sealer to protect from corrosion.

To minimize corrosion of the internal motor components that may occur due to condensation, power the winch in or out periodically. Energizing the motor will generate heat, which will help dissipate any moisture buildup in the motor. This should be performed at periodic intervals (such as with each oil change of your vehicle).

Note: Refer to the Troubleshooting Guide if the motor has been submerged.

Cable Installation

1. Unwind the new cable by rolling it out along the ground to prevent kinking.
2. Remove the old cable and observe the manner in which it is attached to the cable drum.
3. Before installing the new cable assembly, securely wrap the end of the cable with plastic tape or similar tape to prevent fraying.
4. Position the cable drum so that the large 13/32" diameter hole in the drum flange is approximately at the top.
5. Feed the end of the rope opposite the hook through the fairlead and form a short bend (approximately 1/2" long) in the end of the cable. Insert the bend into the 13/32" hole in the drum flange and then carefully run the winch in the "reel in" direction approximately 3/4 revolution until the 1/4" diameter threaded hole in the drum flange is on top.
6. Secure the cable to the drum flange using the cable anchor and capscrew shown in the parts diagram on page 8. Securely tighten the capscrew, but do not over-tighten.
7. Wind 5 wraps of cable onto the drum. Wind on the rest of the cable by pulling in a light load to keep tension constant. Allow the cable to swivel by using a length of chain or swivel block between the cable hook and the load.

Troubleshooting Guide

CONDITION	POSSIBLE CAUSE	CORRECTION
MOTOR RUNS IN ONLY ONE DIRECTION	Defective solenoid or stuck solenoid Defective remote control switch	Jar each solenoid to free contacts. Check each solenoid by applying 12 volts to coil-terminal (it should make an audible click when energized). Disengage winch clutch, remove remote control switch from the socket and jump pins at 8 and 4 o'clock. Motor should run. Jump pins at 8 and 10 o'clock. Motor should run.
MOTOR RUNS EXTREMELY HOT	Long period of operation Insufficient Battery	Cooling-off periods are essential to prevent overheating. Check battery terminal voltage under load. If 10 volts or less, replace or parallel another battery to it.
MOTOR RUNS, BUT WITH INSUFFICIENT POWER OR WITH LOW LINE SPEED	Bad connection Insufficient charging system	Check battery cable for corrosion; clean and grease. Replace with larger capacity charging system.
MOTOR RUNS, BUT DRUM DOES NOT TURN	Clutch not engaged	If clutch engaged but symptoms still exist, it will be necessary to disassemble winch to determine cause and repair.
MOTOR WILL NOT OPERATE	Defective solenoid or stuck solenoid Defective remote control switch Defective motor. Loose connections	Jar each solenoid to free contacts. Check each solenoid by applying 12 volts to coil-terminal (it should make an audible click when energized). Disengage winch clutch, remove remote control switch from the socket and jump pins at 8 and 4 o'clock. Motor should run. Jump pins at 8 and 10 o'clock. Motor should run. If solenoids operate, check for voltage at armature post; replace motor. Check connections for quick connect battery lead to battery and quick connect motor lead to winch.
MOTOR WATER DAMAGED	Submerged in water or water from high pressure car wash.	Allow to drain and dry thoroughly, then run motor without load in short bursts to dry windings.

QUICK MOUNT 9000

Инструкция RAMSEY QM9000

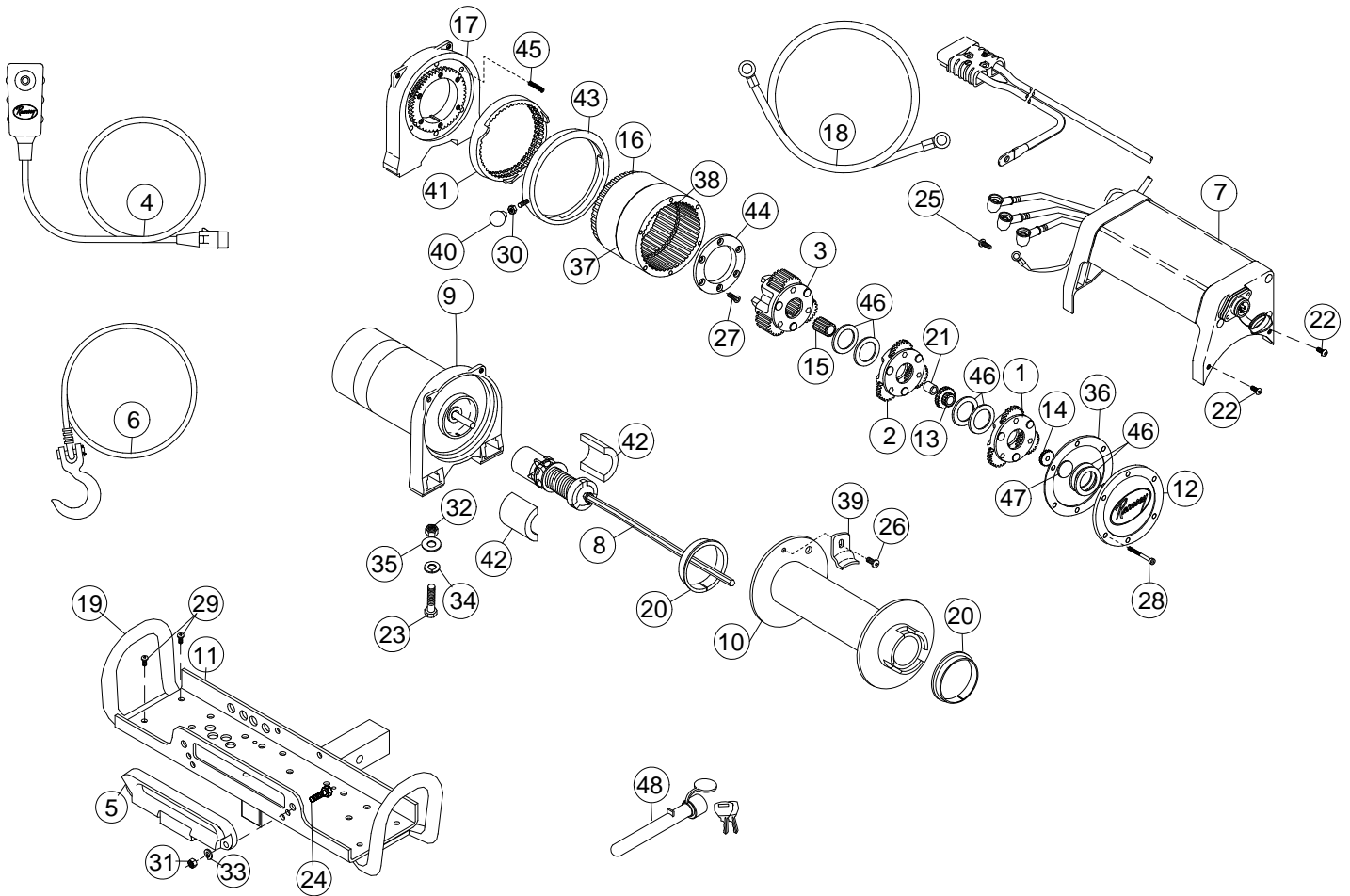

Item	Qty.	Parts No.	Description	Item	Qty.	Parts No.	Description
1	1	247009	GEAR CARRIER ASSEMBLY - INPUT	25	1	416212	SCREW #10-24NC X 3/8 LG. SOC. BUTT. HD. Z/P
2	1	247022	GEAR CARRIER ASSEMBLY - INTERMEDIATE	26	1	414830	CAPSCREW - 1/4-20NC X 3/8 SOC BUTTON HD
3	1	247023	GEAR CARRIER ASSEMBLY - OUTPUT	27	6	414861	CAPSCREW - 1/4-20NC X 3/4 FLT SOCHD NYLOK
4	1	282001	SWITCH ASSEMBLY -12 FT	28	6	414868	CAPSCREW - 5/16-18NC X 2 1/2 LG. SOC HD NYLOK
	1	282012	SWITCH ASSEMBLY -25 FT	29	4	414937	CAPSCREW - 3/8-16NC X 3/4 HX SOC BUTTON HD
5	1	251152	HAWSE FAIRLEAD ASSEMBLY	30	1	418029	NUT - 5/16-24NF HEX JAM Z/P
6	1	251210	CABLE ASSEMBLY	31	2	418033	NUT - 3/8-16NC HEX REG F/B
7	1	278180	SOLENOID	32	4	418035	NUT - 3/8-16NC HEX REG Z/P
8	1	296181	BRAKE ASSEMBLY	33	2	418175	LOCKWASHER - 3/8 MED F/B
9	1	296569	MOTOR ASSEMBLY - 3.6HP	34	5	418177	LOCKWASHER - 3/8 MED Z/P
10	1	296573	DRUM ASSEMBLY	35	4	418181	FLAT WASHER - /38 ID SAE Z/P
11	1	299697	QM PLATFORM ASSEMBLY	36	1	442208	GASKET - GEAR HSG COVER
12	1	328138	GEAR HOUSING COVER	37	1	442219	GASKET - RING GEAR
13	1	334147	GEAR - INTERMEDIATE SUN	38	1	444077	GEAR - INPUT & INTERMEDIATE RING
14	1	334154	GEAR - INPUT SUN	39	1	448046	CABLE ANCHOR
15	1	334197	GEAR - OUTPUT SUN	40	1	452001	KNOB
16	1	334171	GEAR - OUTPUT RING	41	1	477002	LOCKING RING
17	1	338337	END BEARING - GEAR HOUSING	42	2	477004	RING - HALF
18	1	289141	CABLE ASSEMBLY - GROUND	43	1	477011	CAM RING
19	2	395294	QM HANDLE	44	1	479007	RETAINER - RING GEAR
20	2	412056	BUSHING - DRUM	45	6	494077	SPRING
21	1	412061	BUSHING - SHAFT	46	6	518020	THRUST WASHER
22	4	414823	CAPSCREW - 1/4-20NC X 3/4 LG. SOC. BUTT. HD. F/B	47	1	518027	THRUST DISC
23	4	414316	CAPSCREW - 3/8-16NC X 1-1/4 HX HD Z/P GR5	48	1	448097	LOCKING PIN
24	2	414320	CAPSCREW - 3/8-16NC X 1-1/4 HX HD F/B GR5				

QUICK MOUNT 9500

Инструкция RAMSEY QM9000

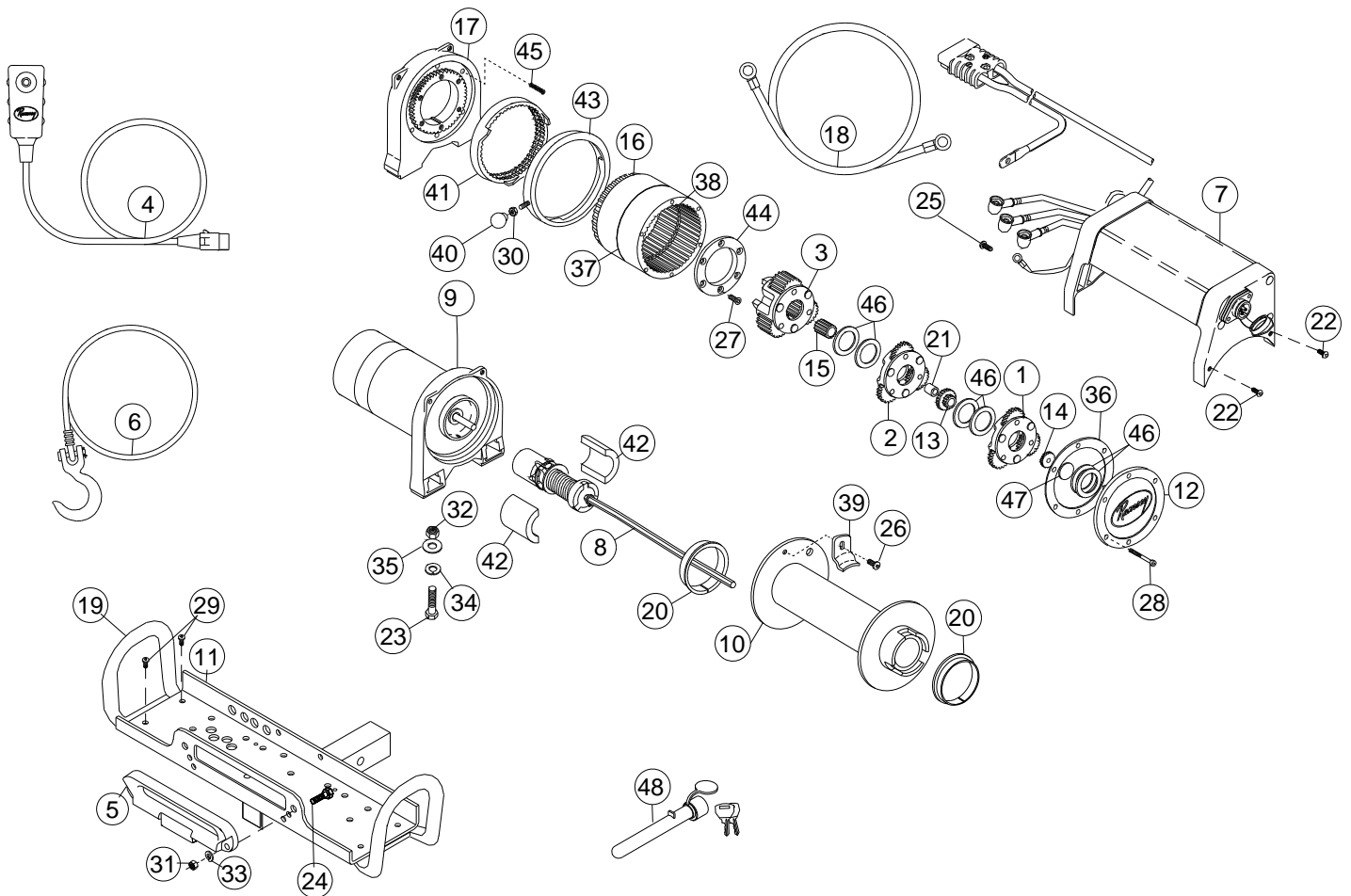

Item No.	Qty.	Parts No.	Description	Item No.	Qty.	Parts No.	Description
1	1	247009	GEAR CARRIER ASSEMBLY - INPUT	25	1	416212	SCREW #10-24NC X 3/8 LG. SOC. BUTT. HD. Z/P
2	1	247022	GEAR CARRIER ASSEMBLY - INTERMEDIATE	26	1	414830	CAPSCREW - 1/4-20NC X 3/8 SOC BUTTON HD
3	1	247023	GEAR CARRIER ASSEMBLY - OUTPUT	27	6	414861	CAPSCREW - 1/4-20NC X 3/4 FLT SOCHD NYLOK
4	1	282001	SWITCH ASSEMBLY -12 FT	28	6	414868	CAPSCREW - 5/16-18NC X 2 1/2 LG. SOC HD NYLOK
		282012	SWITCH ASSEMBLY -25 FT	29	4	414937	CAPSCREW - 3/8-16NC X 3/4 HX SOC BUTTON HD
5	1	251152	HAWSE FAIRLEAD ASSEMBLY	30	1	418029	NUT - 5/16-24NF HEX JAM Z/P
6	1	251210	CABLE ASSEMBLY	31	2	418033	NUT - 3/8-16NC HEX REG F/B
7	1	278180	SOLENOID	32	4	418035	NUT - 3/8-16NC HEX REG Z/P
8	1	296181	BRAKE ASSEMBLY	33	2	418175	LOCKWASHER - 3/8 MED F/B
9	1	296570	MOTOR ASSEMBLY - 4.8HP	34	5	418177	LOCKWASHER - 3/8 MED Z/P
10	1	296573	DRUM ASSEMBLY	35	4	418181	FLAT WASHER - /38 ID SAE Z/P
11	1	299697	QM PLATFORM ASSEMBLY	36	1	442208	GASKET - GEAR HSG COVER
12	1	328138	GEAR HOUSING COVER	37	1	442219	GASKET - RING GEAR
13	1	334147	GEAR - INTERMEDIATE SUN	38	1	444077	GEAR - INPUT & INTERMEDIATE RING
14	1	334154	GEAR - INPUT SUN	39	1	448046	CABLE ANCHOR
15	1	334197	GEAR - OUTPUT SUN	40	1	452001	KNOB
16	1	334171	GEAR - OUTPUT RING	41	1	477002	LOCKING RING
17	1	338337	END BEARING - GEAR HOUSING	42	2	477004	RING - HALF
18	1	289141	CABLE ASSEMBLY - GROUND	43	1	477011	CAM RING
19	2	395294	QM HANDLE	44	1	479007	RETAINER - RING GEAR
20	2	412056	BUSHING - DRUM	45	6	494077	SPRING
21	1	412061	BUSHING - SHAFT	46	6	518020	THRUST WASHER
22	4	414823	CAPSCREW - 1/4-20NC X 3/4 LG. SOC. BUTT. HD. F/B	47	1	518027	THRUST DISC
23	4	414316	CAPSCREW - 3/8-16NC X 1-1/4 HX HD Z/P GR5	48	1	448097	LOCKING PIN
24	2	414320	CAPSCREW - 3/8-16NC X 1-1/4 HX HD F/B GR5				

Solenoid Assembly Parts List: QM 9000/9500

278180 12v QM 9000/9500

Item No.	Qty.	Part No.	Description	Item No.	Qty.	Part No.	Description
1	1	289195	WIRE ASSEMBLY - #2 GA 13.25" MOTOR LEAD	11	1	440180	WIRE ASSEMBLY - 24" QUICK CONNECT
2	2	289196	WIRE ASSEMBLY - #2 GA 14.5" MOTOR LEAD	12	1	440259	STRAP - COPPER
3	1	316101	CAP - LH END	13	3	440260	STRAP - COPPER
4	1	316103	CAP - RH END	14	4	440262	SOLENOID - 12V
5	1	413078	COVER - ASSEMBLY	15	1	440276	WIRE ASSEMBLY - SOLENOID GROUND
6	6	414880	CAPSCREW - 5/16-18NC X 1-1/2 HX SOC F/B	16	1	442222	GASKET
7	3	416207	SCREW - #8-32NC X 3/8 HX SOC BUTT HEAD F/B	17	1	472047	GROMMET
8	2	416227	SCREW - #10-24NC X 3/4 TRUSS RECESS F/B	18	1	482029	COVER - FEMALE RECEPTACLE
9	1	430022	CONNECTOR - FEMALE RECEPTACLE	19	1	682166	COVER - WIRE
10	1	440138	TIE - CABLE	20	1	682167	CHANNEL - SOLENOID

<http://www.bigfoottrade.kz/shop/a0736d5c.html>

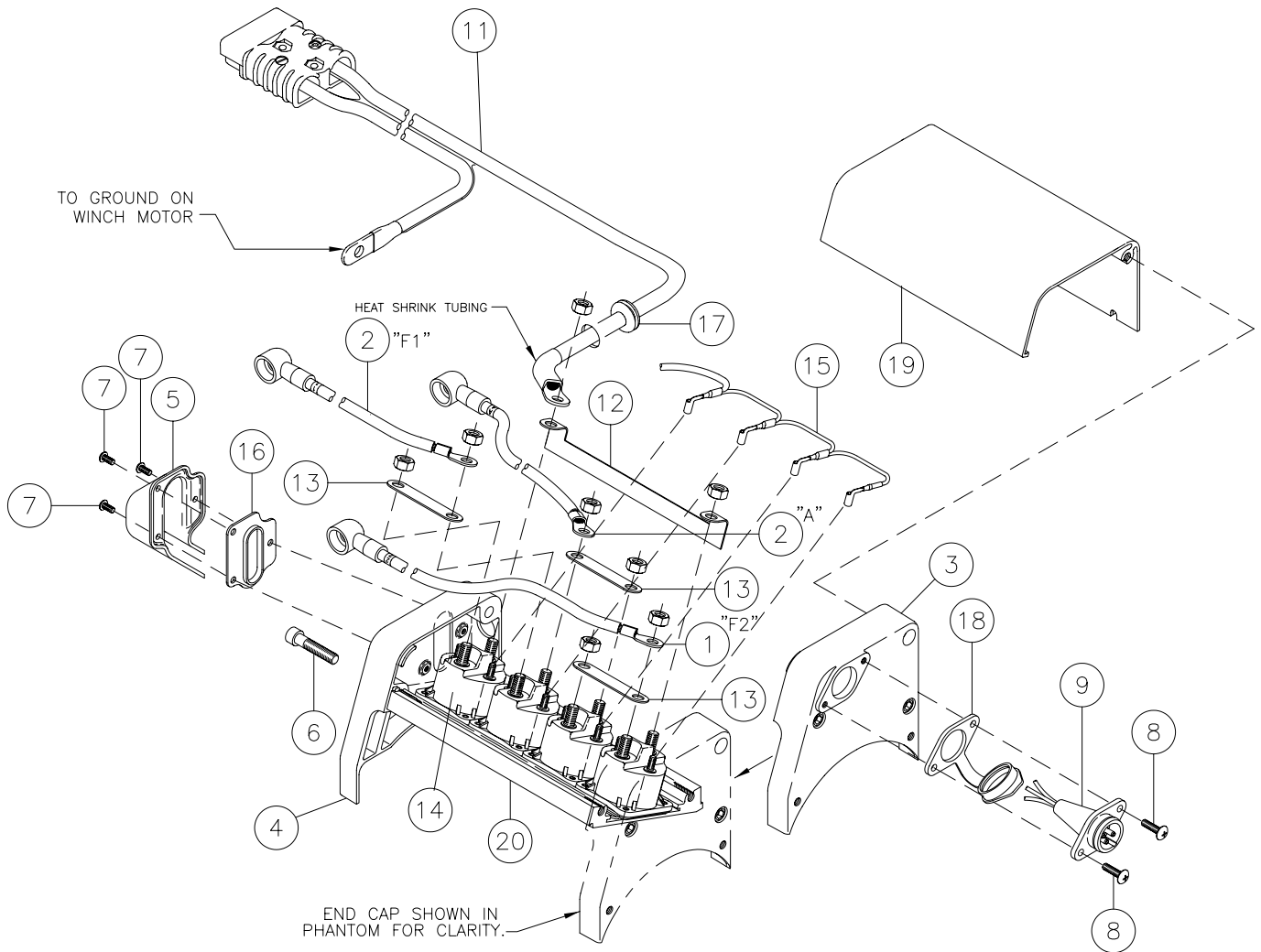

Warranty Information

Ramsey Winches are designed and built to exacting specifications. Care and skill go into every winch we make. If the need should arise, the warranty procedure is outlined on the back of your self-addressed postage paid warranty card. Please read and fill out the enclosed warranty card and send it to Ramsey Winch Company. If you have any problems with your winch, please follow instructions for prompt service on all warranty claims.

Limited Lifetime Warranty

Ramsey Winch offers a limited lifetime warranty for each new Ramsey consumer/RV winch against manufacturing defects in workmanship and materials on all mechanical components.

Warranty registration cards for each winch must be submitted at the time of purchase or within 30 days. Warranty will only be valid for the original purchaser of the winch and installed on the vehicle with which it was originally registered.

New cable assemblies are warranted against defects in workmanship and materials. No warranty applies after initial use.

All Ramsey mounting kits and other accessories carry a 1-year limited warranty against defects in materials and workmanship.

This warranty is void if winch is used in commercial/industrial applications other than front mount self recovery.

Electrical components consisting of motors, solenoids, wiring, wire connectors, and associated parts carry a 1-year limited warranty. Battery isolators carry a 90-day limited warranty.

The obligation under this warranty, statutory or otherwise, is limited to the replacement or repair at the manufacturer's factory, or at a point designated by the manufacturer, of such part as shall appear to the manufacturer, upon inspection of such part, to have been defective in material or workmanship. This warranty does not obligate Ramsey Winch Company to bear the cost of labor or transportation charges in connection with the replacement or repair of defective parts, nor shall it apply to a product upon which repairs or alterations have been made, unless authorized by the manufacturer, or for equipment misused, neglected, or improperly installed.

Important Notice: To the fullest extent permitted by applicable law, the following are hereby excluded and disclaimed: 1. All warranties of fitness for a particular purpose. 2. All warranties of merchantability; 3. All claims of consequential or incidental damages. There are no warranties that extend beyond the description that appears on the face hereof.

Some states do not allow the above exclusions or disclaimers in consumer transactions and as such this disclaimer/exclusion may not apply to your particular case.

To the extent such warranties of fitness for a particular purpose or merchantability are deemed to apply to this product, they exist for only so long as the express limited warranty elsewhere set forth in existence.

Ramsey Winch Company makes no warranty in respect to accessories, same being subject to the warranties of their respective manufacturers.

Ramsey Winch Company, whose policy is one of continuous product improvement, reserves the right to improve any product through changes in design or materials as it may deem desirable without being obligated to incorporate such changes in products of previous manufacture.

If field service at the request of the buyer is rendered and the fault is found not to be with Ramsey Winch Company's product, the buyer shall pay the time and expense cost of the field representative. Bills for service, labor, or other expenses which have been incurred by the buyer without express approval or authorization by Ramsey Winch Company will not be accepted.

This warranty gives you specific legal rights and you may also have other legal rights which vary from state to state.



BIG FOOT TRADE
<http://www.bigfoottrade.kz/shop/a0736d5c.html>